

SAVWINCH POT HAULER

900PH

OPERATING & INSTALLATION INSTRUCTIONS

(MUST BE READ PRIOR TO INSTALLATION AND OPERATION)

Contents

INTRODUCTION.....	3
IMPORTANT INFORMATION.....	3
SAFE OPERATION.....	3
INSTALLATION INSTRUCTIONS.....	3
HANDY HINTS.....	3
TECHNICAL DETAILS.....	4
ELECTRICAL	4
Circuit breaker (if required).....	4
Deck Switches.....	4
Isolating Switch.....	4
Batteries.....	4
Solenoid Installation.....	5
OPERATING INSTRUCTIONS.....	5
Anchoring.....	5
MAINTENANCE AND SERVICING.....	6
Servicing.....	6
Line Care.....	6
Rope/Chain Splice.....	6
ELECTRICAL DIAGRAM/SCHEMATIC.....	7
CORROSION PROTECTION.....	7
DECK TEMPLATE.....	8

INTRODUCTION

Thank you for purchasing a Windlass. We go to great lengths to develop anchoring systems that not only meet all your performance and safety requirements, but at the same time are designed with a style and finish that enhances the aesthetics of your vessel. With our commitment to quality and the use of superior materials and processes we know you will be pleased with your investment, and rest assured that through the correct installation, operation and maintenance your new Windlass will give you years of reliable performance.

IMPORTANT INFORMATION

To avoid damage to the capstan or vessel when retrieving the anchor, it is a preferred practice to mark the rope/chain at approximately 5-meter intervals from the anchor, to alert the operator to the anchor position.

Under no circumstances should the windlass be operated if it is stalled or overloaded.

SAFE OPERATION

- Ensure that hands, feet, hair and clothing are kept clear of the windlass and other loose gear when in operation.
- The capstan should never be used for lifting people aloft.
- Do not use a capstan as a bollard for mooring, towing or being towed.

INSTALLATION INSTRUCTIONS

Locate the capstan in a suitable position on the deck so there is no interference from other ropes or objects (the rope has a clear lead to the winch), so that there is working room and you can tail the line comfortably.

Ensure that there is sufficient room to run the electrical cables to the winch underneath the deck.

If the deck is angled or curved a suitably shaped mounting block will be required to spread the load evenly over the deck surface and mount the winch on a level and even footing. Depending on the thickness of the deck, a suitable spacer below deck may be required to mount the winch. Place the shaped mounting block (if required) onto the deck. Use the layout template dimensions to mark the hole centres and then drill/cut out the holes.

Apply an appropriate sealant to the base plate and mounting block (if required), taking care to align mounting holes when assembling. For Aluminium or Steel hull vessels, it is important to insulate the capstan with a non-conductive gasket to avoid corrosion. This also applies below deck with the mounting bolts, nuts and washers. Where the deck construction is light or of foam sandwich construction, a plywood stiffener of at least 16mm (5/8") should be fitted to the underside of the deck to spread the load. Install and tighten mounting bolts.

For recommended Electrical installation, please review electrical section.

HANDY HINTS

Ensure sufficient room to run electric cables to the capstan winch. Follow the instructions above including underdeck stiffening, alignment, mounting blocks and sealing procedures.

Position the capstan carefully checking desired rope path before mounting capstan to your deck.

TECHNICAL DETAILS

Motor	900w x 12v Permanent Magnet Motors
Capstan	Stainless steel 316
Base Plate	Marine grade hard anodised and sealed aluminium
Gearbox	Two stage balanced epicyclic
Deck studs	Supplied with nuts in stainless steel
Weight	8kg (18lbs)
Rotation	Clockwise or right hand.
Brake	Auto action roller clutch - will not run back
Cable Size	Boats to 11 metre (36ft) use 25 mm ² - 3awg
Accessories	Covered switch with flip top cover, supplied as standard Circuit breaker supplied as an option.
Winch sizing	There are no absolute rules about winch size to boat size. This product is designed for use on typical private pleasure craft. Winch / boat sizes shown are based on installations that have proved satisfactory for many years.

ELECTRICAL

See Wiring Diagrams for wiring instructions.

Circuit breaker (if required)

If the drum winch is overloaded or stalled the circuit breaker automatically cuts off power to the winch and protects the wiring and motor. The circuit breaker should not be used as an isolating switch, for safety reasons. N.B. Circuit breaker is not normally required in a capstan application.

Deck Switches are best located to either port or starboard or directly behind the capstan in a position where it can be easily reached with your foot or knee, preferably where you can view the anchor and chain coming aboard.

Isolating Switch should be fitted in an accessible position for safety, ideally close to the battery or switches. The isolating switch is not a circuit breaker.

Batteries are best located as close to the capstan as possible. Larger cables will reduce the voltage drop to the motor and the heat generated when operating the winch. Small diameter cables drop voltage considerably. Use the following table as a guide to your required wire size: (Based on 1500W 12V Motor)

Distance from battery to motor (m)	Cable Size		Cable Core Diameter (mm)
	(mm ²)	AWG	
< 8 (26')	25	3	7 (17/64")
9 - 12 (29' - 39')	35	2	8 (5/16")
13 - 18 (42' - 60')	50	1/0	9 (23/64")

Solenoid Installation

We recommend that the solenoid is installed in an upright position, where it has minimal exposure to sea water and in close proximity to the electric motor of the winch.

For wiring information, please refer to the wiring diagram/schematic.

WINCH MODEL	MOTOR SIZE	MOTOR TYPE
(900PH)	900W	2 POLE

OPERATING INSTRUCTIONS

It is advisable to "mark" the anchor end of the chain/rope at 2 and 5 metre (6.5' & 16.5') intervals which will enable the operator to judge when the anchor is almost up.

Anchoring: Lower the anchor as you reverse the boat, this allows the anchor and chain to layout properly on the sea bed. Lower the anchor until the rope is slack and/or you are in the right position, once there it is recommended to tie off the rope to a cleat or bollard, or use a snubber.

To retrieve/raise the anchor, stand or kneel behind the winch and simply wind up to three turns (maximum) of line or sheet around the drum in a clockwise direction. Maintain a light "tailing" pull onto the free end and start the capstan. As the capstan rotates, lightly pull the line hand over hand keeping up with the speed of the winch. The capstan does all the hard work for you. Stop and hold at any time. **Do not use your hands or feet on the anchor side of the capstan drum to adjust the rope as it may become caught and entangled in the winch drum.**

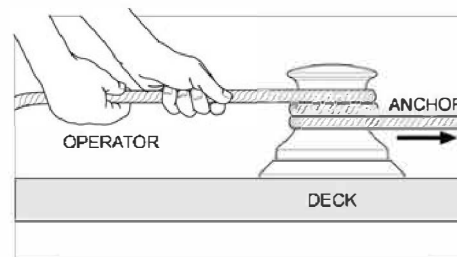

When recovering your anchor, first start the engine. In strong winds, tides, currents or in deep water, use a little engine power to come up over the anchor as the capstan is used. Never stall the capstan and do not run it at low speed for any extended time. Use one continuous and smooth recovery and do not repeatedly start/stop. If the anchor is stuck, use a little engine power and the weight of the boat to break it free.

Also take care not to run over the anchor rope and entangle it in your prop or rudder. Go gently with the last two metres of retrieving the anchor, rather than waiting for the anchor to fly up over the roller and bang tight, putting excessive load onto the bow roller, winch and fore deck. When the weather is rough, anchoring overnight or traveling, it is not recommended to use the capstan as a mooring bollard!! Secure the rope around a cleat or bollard, or use a snubber to take the load.

MAINTENANCE AND SERVICING

Servicing

Every 6 months, remove centre screw from top of the capstan drum and lift drum off.

Lightly grease the synthetic bearings under the drum.

Smear a little grease on the O ring seal in the top outer cap, assemble and tighten firmly.

The motor is made of steel and may corrode if the paint system is damaged.

Check the motor regularly and keep dry and clean.

In "dry" installations, spray the motor regularly with a water repellent (CRC or WD40).

In damp or "wet" installations, including situations where a lot of condensation takes place, treat the motor and terminals regularly with CRC "soft seal" or similar.

Check all terminals in the system and protect as described above.

In the case of Work and Charter Vessels we suggest it is carried out more frequently.

Line Care

The winches are designed to run on 3-strand nylon line which has been specially treated with fabric softener to prevent it from hardening. It is recommended to soak your rope in fresh water containing fabric softener every 3 months.

ELECTRICAL DIAGRAM/SCHEMATIC

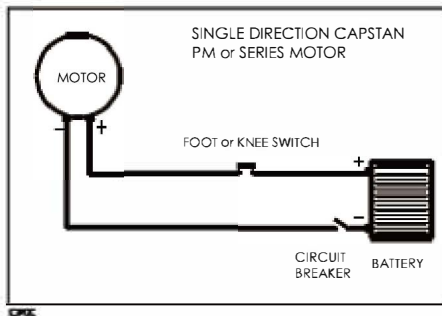

WIRING NOTES.

Solenoid packs and electrical equipment should be placed in a dry, well ventilated area.
Avoid installation in anchor locker.

Standard winches are set up at the factory to run clockwise (as viewed from above) when hauling. If, after wiring, a single direction winch will not run, try changing heavy cables over at the motor.

When testing initially, stab operate winches with short action. After satisfactory testing of winch, coat motor terminals and oil terminals in the system with CRC 'Softseal' or equivalent.

ATTENTION !

900PH will ONLY work in clockwise direction.

Always connect Positive (+) Terminal on the Battery to the Positive (+) Terminal on 900PH Electric Motor.
Always connect negative (-) Terminal on the Battery to the negative (-) Terminal on 900PH Electric Motor.

If wired incorrectly it will damage the Electric Motor and VOID the Warranty

CORROSION PROTECTION - for long life (general notes for all winches).

The motor and some underdeck parts of your winch are manufactured from materials that require protection from the marine environment. Paint and other protection systems are applied at time of manufacturer, but additional protection and regular inspection is necessary after installation.

Immediately after installation we recommend that the winch is tested. Reversing winches should be run in forward, reverse and manual modes. Rope only winches will only run one way unless ordered otherwise. Observe polarity indicated by +/- labels on motor. Check all terminals and fastenings are firmly secured. Coat all underdeck surfaces and terminals with CRC 'Softseal', automotive underseal or similar. Control equipment should never be installed in damp positions such as the chain locker, but, if necessary, control equipment will need protection too.

Service checks. Check motors and underdeck parts regularly for signs of corrosion and take necessary action immediately. Above deck items need maintenance too, including cleaning, greasing/oiling per instructions issued with the winch. If cone cutches (where fitted) are found to stick, release clutch nut and give one of the gypsy teeth a smart rap with a hard wood or brass drift. When the clutches free up, a very light spray with CRC / WD40 will help prevent further sticking.

WARNING. Motor, brake, gearbox assembly should never be removed or fastenings loosened during installation. Some fastenings are sealed with a locking compound and warranty may be void if any seal is broken. If a fault is suspected during the warranty period DO NOT remove any parts or attempt a repair. Return the complete unit to the factory via supplier with evidence of purchase and detail of problem experienced.

FAILURE or DAMAGE due to improper maintenance is not covered by warranty.