

# Series 55 BB

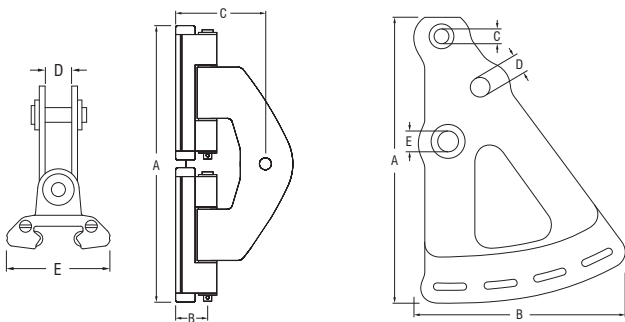

18mm (23/32") pin diameter  
Bushed to 32mm (1 1/4") diameter



✓ Custom headboard cars, headboards and batten cars can be designed and manufactured to suit more demanding applications or individual requirements.

⬆ Monohulls to 45m (148ft) or sail area 400m<sup>2</sup> (4306ft<sup>2</sup>).

⬆ Multihulls to 33m (110ft) or sail area 300m<sup>2</sup> (3229ft<sup>2</sup>).

PRODUCT No.	DESCRIPTION	A	B	C	D	E	WEIGHT	A	B	C	D	E	WEIGHT
		mm	mm	mm	mm	mm	g	in	in	in	in	in	oz
<b>Series 55 BB</b>													
RC00014	Headboard plate	490	315	25.4	30.0	34.4	6880	19 5/16	12 7/16	1	1 5/32	1 5/16	242.7
RC15560	Headboard car	605	74	200	34	126	15160	23 13/16	2 15/16	7 7/8	1 5/16	5	534.8
<b>Spare Parts</b>													
501005	Ball bearing, Torlon®, 12.7mm (1/2") diameter	-	-	-	-	-	2	-	-	-	-	-	0.2



© Wilhelm Schurmann

✓ Custom headboard cars, headboards and batten cars can be designed and manufactured to suit more demanding applications or individual requirements.

⚡ Monohulls to 52m (170ft) or sail area 700m<sup>2</sup> (7500ft<sup>2</sup>).

⚡ Multihulls to 39m (128ft) or sail area 525m<sup>2</sup> (5650ft<sup>2</sup>).

PRODUCT No.	DESCRIPTION	A	B	C	D	E	WEIGHT	A	B	C	D	E	WEIGHT
		mm	mm	mm	mm	mm	g	in	in	in	in	in	oz
<b>Series 55 BB</b> RC15561	Headboard car	710	74	204	34	126	18300	28	2 15/16	8	1 5/16	5	647.0